

Typical Hydraulic Circuits

CYLINDERS

Pumps, Cylinders and hydraulic control schematics of basic systems for reference...

These are just a few basic systems possible with Power Team hydraulic components. Countless applications are possible: In

1 Single-acting cylinder or cylinders in the circuit, controlled by a pump mounted valve.

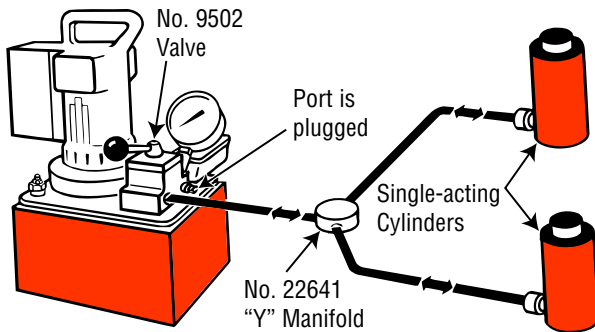

2 Double-acting cylinder or cylinders in the circuit, controlled by a pump mounted valve.

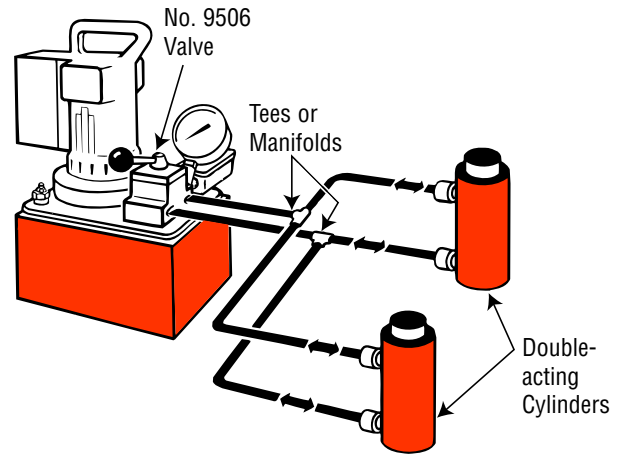

3 Single-acting cylinder controlled by a remote mounted valve.

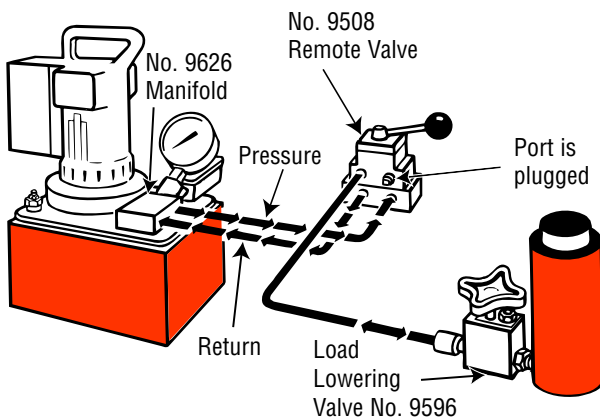

4 Double-acting cylinders controlled by a remote mounted valve.

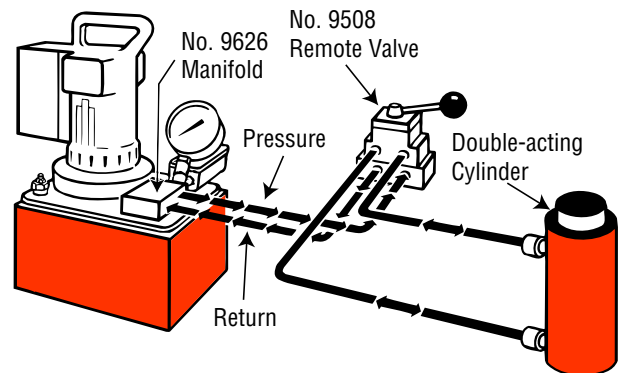

5 Single-acting cylinders with a sequence valve which controls the primary and secondary cylinder circuits.

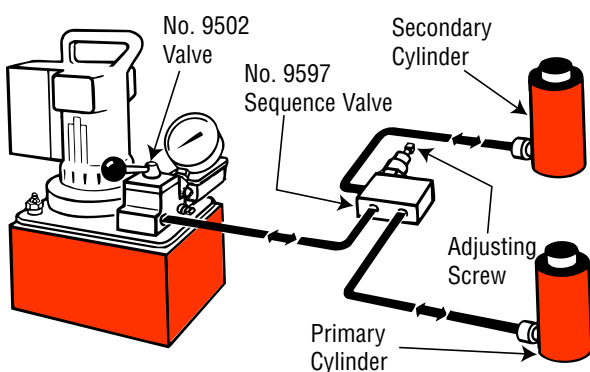

6 Double-acting cylinder with a sequence valve which controls the primary and secondary cylinder circuits.

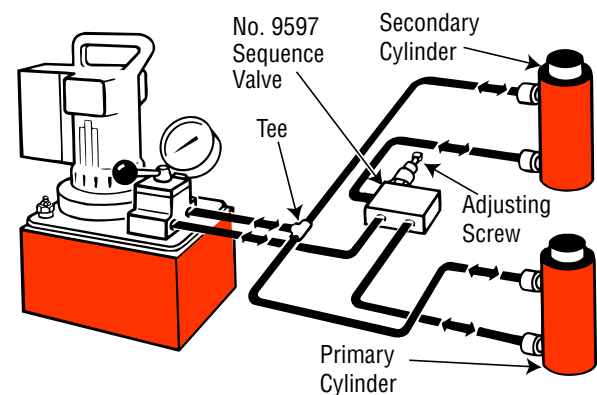

Basic single-acting system with a hand pump, gauge, hose and single-acting cylinder.

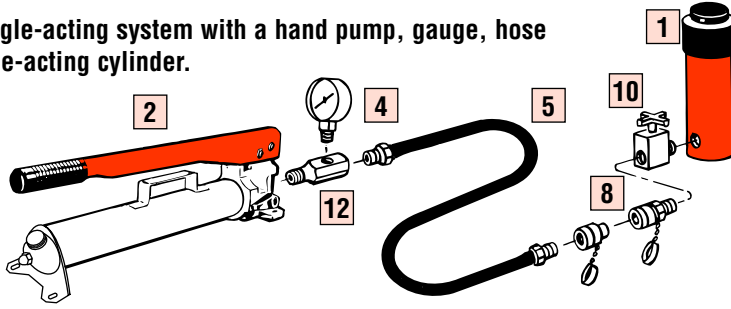

Basic single-acting system with a hand pump, gauge, hose, multiple shut-off valves, load-lowering valves and multiple cylinders.

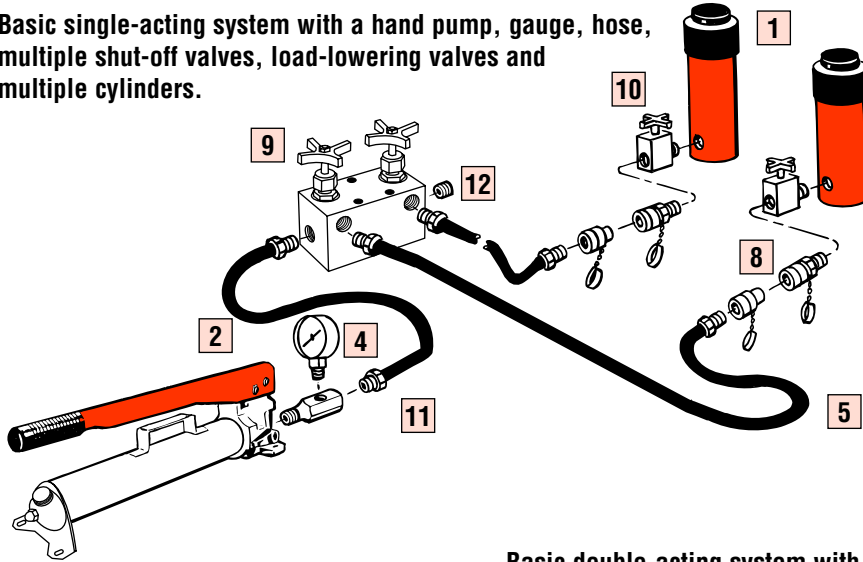

Basic double-acting system with an electric/hydraulic pump, shut-off valves, load-lowering valves and multiple double-acting cylinders.

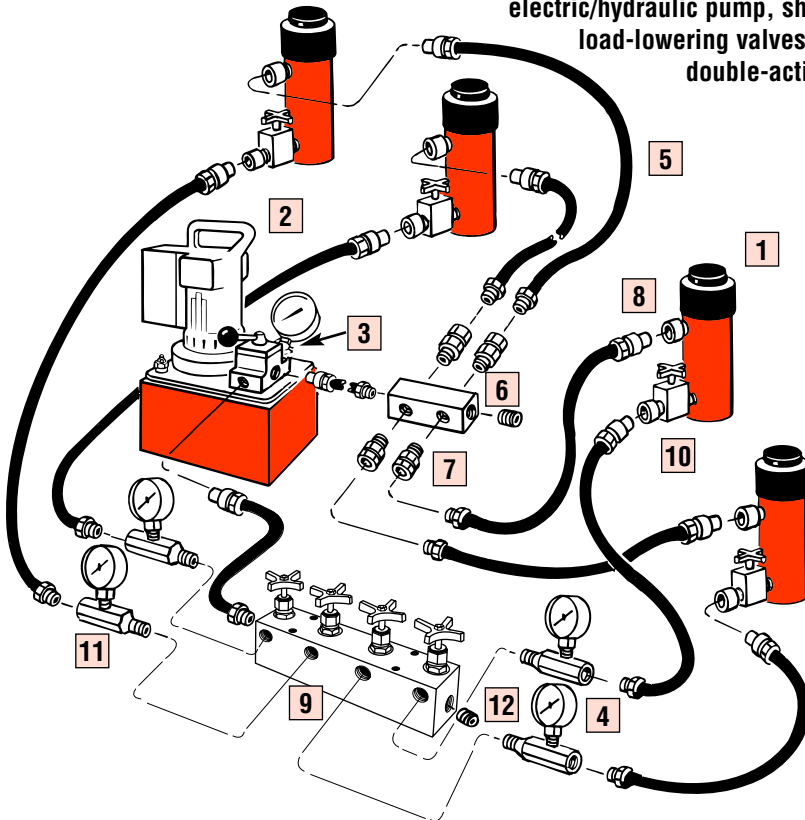

- 1 Cylinder** – applies hydraulic force.
- 2 Pump** – a device for converting mechanical energy to fluid energy.
- 3 Directional valve** – controls the direction of hydraulic fluid in the system.
- 4 Gauge** – measures Bar pressure and/or force.
- 5 Hose** – transports hydraulic fluid.
- 6 Manifold** – allows distribution of hydraulic fluid from one source to several cylinders. (No. 9617)
- 7 Swivel Connector** – allows proper alignment of valves and/or gauges. Used when units being connected cannot be rotated. (No. 10469)
- 8 Quick Coupling** – “hose half” and “cylinder half” couplings are used for quick connection and fluid flow check when separated. (No. 9797 and 9798)
- 9 Shut-Off Valve** – regulates the flow of hydraulic fluid to or from cylinders. (No. 9642 or 9644)
- 10 Load-Lowering Valve** – allows metered lowering of cylinder and provides safety when prolonged load holding is required. (No. 9596)
- 11 Tee Gauge Adapter** – allows for installation of pressure/tonnage gauge anywhere in the hydraulic system. (No. 24815)
- 12 Pipe Plug** – for blocking unused ports within the system. (No. 10909)

For additional information on which Power Team products best suit your needs, refer to the “Understanding Power Team Products” section on pages 175-191.