

“Enforcer 100” Universal Puller

100 Ton Capacity

- 1 Adjustable jaws mean they always pull on a flat surface. Retaining chain holds jaws in place during positioning.
- 2 Grip-O-Matic® feature means jaws grip progressively tighter as more pulling force is applied.
- 3 100 ton hydraulic cylinder is single-acting, spring return type with a maximum working pressure of 700 bar.
- 4 Lifting bracket allows puller to be lifted if the work-piece center is more than 914 mm off the floor.
- 5 Adjusting screw allows operator to move vertical position of the puller.
- 6 Spring loaded feature means Enforcer 100 will align itself on uneven pulls.
- 7 Hydraulic pump is a 2-stage, high pressure unit controlled by remote hand switch with 7.6 m cord.
- 8 Tow bar provides puller with plenty of mobility.
- 9 Pushing adapters have a diameter of 105 mm and 63.5 mm.

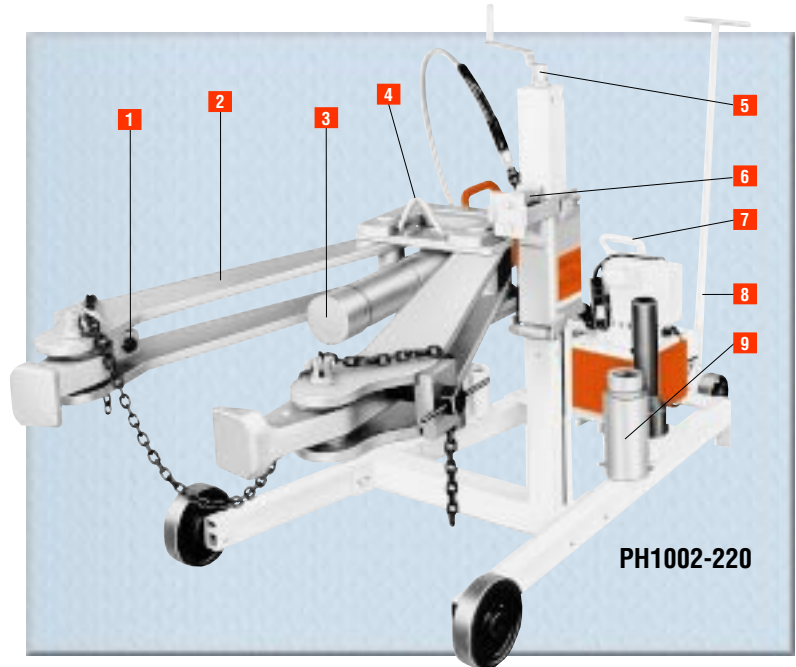

“Enforcer 100” universal puller

No. PH1002-220 – 100 ton, 2-jaw universal hydraulic puller. Includes: 2-jaw Grip-O-Matic® puller, PE552S 2-speed electric/hydraulic power unit, C10010C 100 ton hydraulic cylinder with 260 mm stroke and six adapters. Wt., 404 kg.

No. PH1002J – Same as PH1002-220, but without hydraulic power unit. Wt., 375 kg.

PE552S – Pump only. .84 kW, 220 volt, 50Hz, single phase, draws 13 amps at full load. Also available in 115 volt, 50/60Hz.

Note: For 115 volt, 60/50 Hz applications, order Part No. PH1002.

An ideal puller for steel mills, mines, oil fields, utility projects, paper mills, construction sites, railroads, airline shops, shipyards or anywhere else where large equipment and machinery pose tough maintenance challenges.

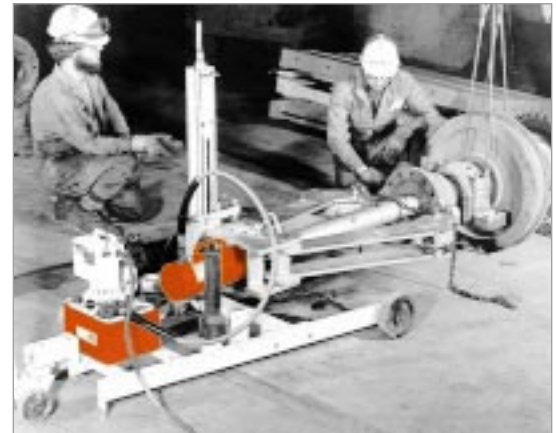

ORDERING INFORMATION *Cart size is 92.7 cm W x 175.3 cm L x 112.4 cm H **See current price list for shipping weights.

Order Number	A	B	C	D	E	F	G	Vertical Height Adjust. (mm)	Overall Length (mm)	H Max. Thickness Workpiece (mm)	Wheel Dia. (mm)	Cylinder Stroke (mm)	Power Source Requirements
	Min. Spread (mm)	Reach at Min. Spread (mm)	Max. Spread (mm)	Reach at Max Spread (mm)	Puller Jaw Tip (mm)								
PH1002-220	381	1067	1219	864	25.4	57.1	127	305-914	2388	305	203	260	220V, 50/60Hz, 13 Amp Cap.
PH1002J	381	1067	1219	864	25.4	57.1	127	305-914	2388	305	203	260	—

Ram extensions

Order No.	Amount included with puller	J (mm)	K (mm)	L (mm)	M (mm)	N (mm)
44745 (Push Adapter)	1	105	—	343	63.5	—
44766 (Ext. Adapter)	4	105	—	—	—	203
303045 (Push Adapter)	1	105	79.4	—	—	—

