

# Bearing and Pulley Pulling Attachments

Used where space does not permit hooking puller jaws directly on part to be pulled.



- “Knife-like” edges fit behind bearings and other hard-to-grip parts for easy removal, even where clearance is limited.
- Usable with both Grip-O-Matic® jaw type pullers and Push-Pullers®.
- All puller blocks are made from forged alloy steel

Fed. Spec.: GGG-P-00781-D

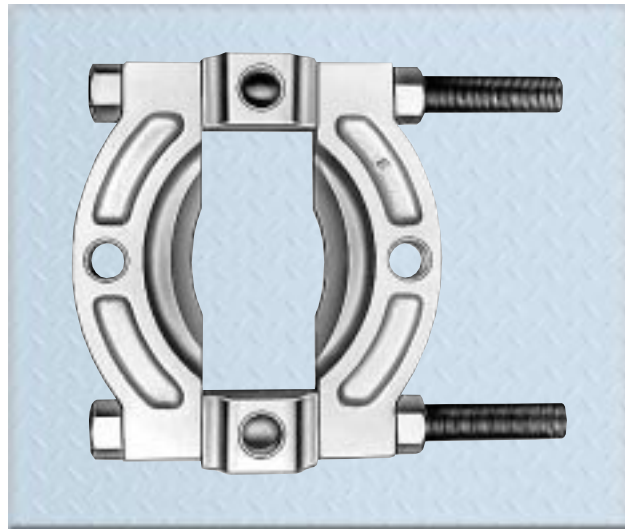

## Cross section specifications

Order No.	A (mm)	B (mm)	C (mm)	D (mm)	E (mm)
1121	11.1	3.2	12.7	34.9	50.8
1122	11.1	4.0	15.9	50.8	69.9
1123	22.2	9.5	25.4	88.9	114.3
1124	34.9	11.1	31.8	127	158.8
1126	34.9	17.5	34.9	146.1	190.5
1127	44.5	17.5	44.5	158.8	215.9
1128	44.5	19.1	57.2	327	406.4
1129	47.6	26.2	69.0	400.1	495.3
1130	34.9	11.1	31.8	127	158.8

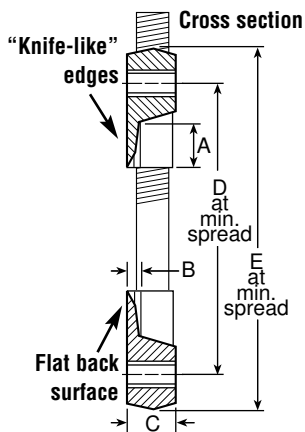

**No. 1121** – Spread: 6.4 mm - 22.2 mm

Wt., 0.3 kg. Use with puller Nos. 1020, 1022 and 1023.

**No. 1122** – Spread: 3.2 mm - 51 mm

Wt., 0.6 kg. Use with puller Nos. 1024, 1025, 1026, 1027, 7392 and 7393.

**No. 1123** – Spread: 9.5 mm - 117 mm

Wt., 2.3 kg. Use with puller Nos. 927, 1035, 1036, 1037 and 1038.

**No. 1124** – Spread: 12.7 mm - 133 mm

Wt., 5.4 kg. Use with puller Nos. 938, 1039, 1040, 1041, 1042, PH172 and PPH17.

**No. 1126** – Spread: 16 mm - 203 mm

Wt., 9 kg. Use with puller Nos. 939, 1043 and 1047.

**No. 1130** – Spread: 12.7 mm - 219 mm

Wt., 5.4 kg. Use with puller Nos. 938, 1039, 1040, 1041, 1042, PH172 and PPH17.

**No. 1127** – Spread: 19 mm - 340 mm

Wt., 18.8 kg. Use with puller Nos. 939, 1047, PH302\* and PPH30.

**No. 1128** – Spread: 127 mm - 327 mm

Wt., 45.4 kg. Use with puller Nos. PH302\*, PH502\*, PH553C and PPH50. (When using 1128 with PPH50, two 8024 adapters are required to connect PPH50 to the puller tees.)

**No. 1129** – Spread: 152 mm - 425 mm

Wt., 89.4 kg. Use with puller Nos. PH502, PH553C and PPH50. (When using 1129 with PPH50, two 8024 adapters are required to connect PPH50 to the puller tees.)

## V-belt pulley pulling attachments

**No. 679** – Spread: 45 mm - 149 mm

Wt., 2 kg. Use with puller Nos. 927, 1035, 1036, 1037 and 1038

**No. 680** – Spread: 42.3 mm - 254 mm

Wt., 10.1 kg. Use with puller Nos. 938, 1039, 1040, 1041, 1042, 1047, PH172 and PPH30. (When using 680 with PPH30, two 8012 adapters are required.)

**CAUTION:** Please refer to page 188.

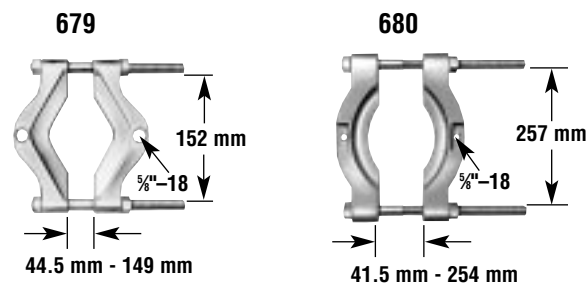
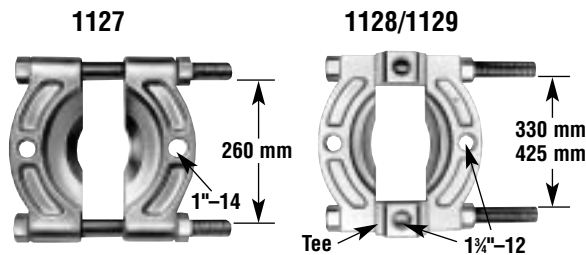
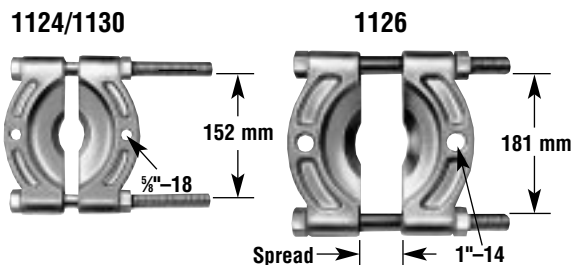
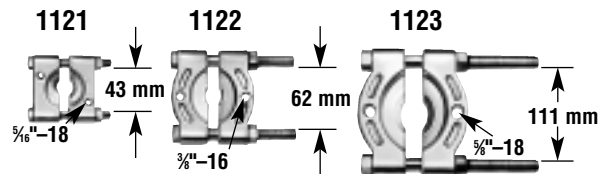
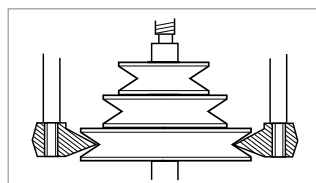

For puller piece part identification, order Power Team parts catalog PC97

\* Indicates discontinued puller model