

Mobile Floor Cranes

1,000 - 2,000 kg Capacity

SHOP EQUIPMENT

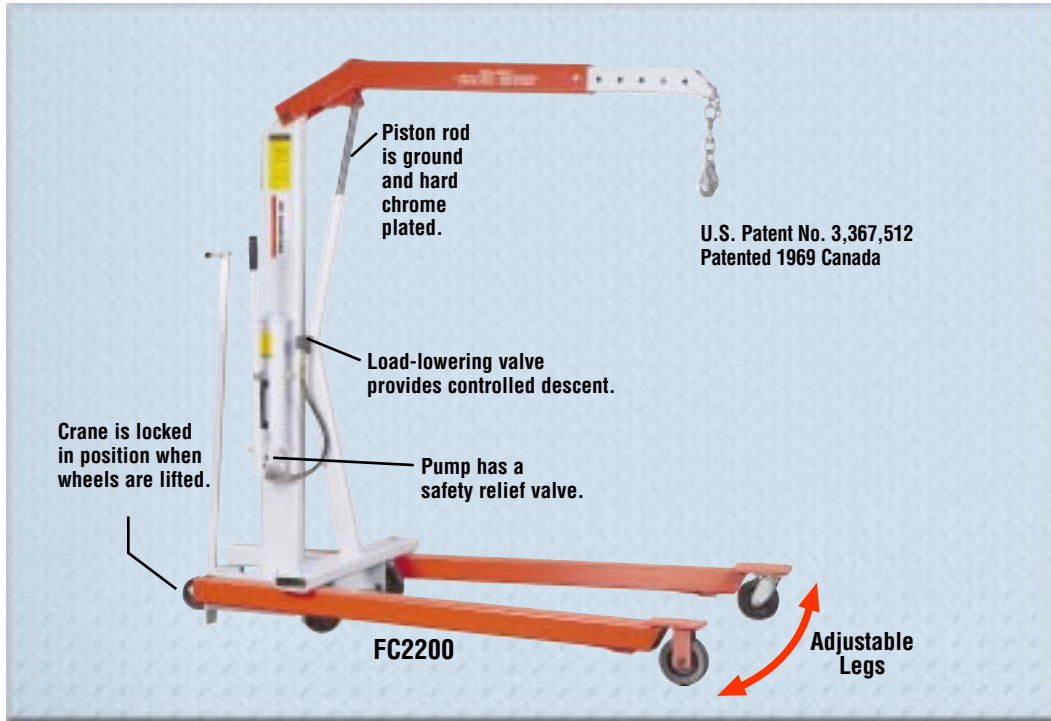

- Adjustable legs spread to clear obstacles, telescoping boom for extra reach. Rugged construction, reliable hydraulics.
- Boom collapses completely and legs fold for compact storage.
- 2-speed hydraulic hand pump provides fast boom travel and precise operator controlled descent.
- Roller bearing wheels and a steering dolly provide ease of mobility. Lifting chain is included.

ORDERING INFORMATION

No. FC2200 – 1,000 kg cap. crane with fold-away feature, adj. leg spread, lifting chain and 2-speed hand pump. Wt., 214 kg.

No. FC4400 – 2,000 kg cap. crane with fold-away feature, adj. leg spread, lifting chain and 2-speed hand pump. Wt., 293 kg.

DIMENSIONS (mm)

	FC2200*	FC4400*
Cap., boom ret. (kg)	1,000	2,000
Cap., boom ext. (kg)	750	1,500
A Max. boom hgt., (ret.)	2,718	2,819
B Max. boom hgt., (ext.)	2,972	3,099
C Overall hgt., boom horiz.	2,032	2,083
D Overall length	2,108	2,261
E Min. throat width	610	635
F Inside leg length	1,372	1,461
G Eff. boom reach (ret.)	838	902
H Eff. boom reach (ext.)	1,219	1,238
J Inside leg width	610-914-1,219 (3-position)	660-1,016-1,333 (3-position)
K Leg height	203	241
L Dolly wheel diameter	127	127
M Wheel diameter	152	203
N Caster diameter	152	152
Floor space, folded	686 x 965	787 x 1,067
Height, folded	2,007	2,184

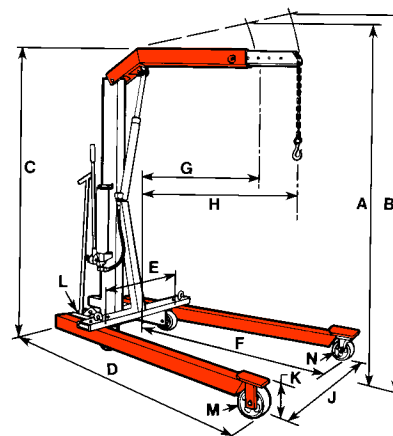

1,000 and 2,000 kg capacity
with space-saving fold-away
feature



* Frame shipped unassembled.