

C Frame Press

25 Ton Capacity



- Can be bench mounted or mounted on optional pedestal base.
- Bench mounted version requires less than .14 sq. m of space; on optional pedestal, only .37 sq. m of floor space is needed.
- “Open Throat” design makes loading and unloading of work easy.
- Cylinder head adjusts to three convenient working positions, providing up to 514 mm of “daylight.”
- Hydraulic cylinder delivers a 159 mm stroke, is driven by a P59 two-speed hand pump.
- **PEDESTAL BASE NO. 60846**
This optional pedestal provides a stable base for your SPM256C. It takes up only about .37 sq. m of space and includes a bracket for mounting the pump on the side of pedestal press. It must be ordered separately. Wt., 34.5 kg.



SHOP EQUIPMENT

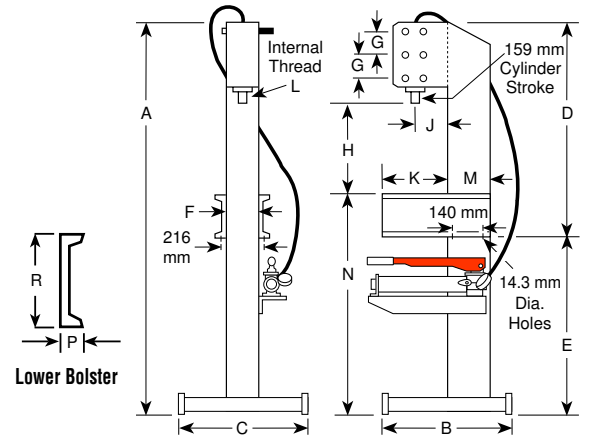

DIMENSIONS

A (mm)	B (mm)	C (mm)	D (mm)	E (mm)	F (mm)	G (mm)	H (Cyl. Retracted) (mm)
1,972	622	610	1,057	914	152	127	260, 387, 514
J (mm)	K (mm)	L (mm)	M (mm)	N (mm)	P (mm)	R (mm)	Floor Space (mm)
165	318	1½-16	203	1,092	51	178	610 x 622

ORDERING INFORMATION

Cap. (tons)	Type Cyl. Used	Stroke	Cyl. Model	Order No.	Speed**		Type Pump	Pump Model	Prod.Wt. (kg)
					Advance	Pressing			
25	Single-Acting	159	C256C	SPM256C*	3.3 mm/stroke	0.8 mm/stroke	Hand	P59	240

* SPM256C does not include No. 60846 pedestal base.

** Typical performance based on pump specifications. Actual speeds may vary with operating conditions.