

H Frame Presses

55 Ton Capacity



- Movable workhead for full off-center pressing at full rated capacity across width of upper frame without buckling or bending.
- Maximum "daylight" is 1,067 mm x 914 mm, making positioning of bulky work pieces easy.

- Height of press bed is easily adjusted with winch; friction brake prevents bed from dropping and handle from spinning upon release.
- 55 ton cylinder has chrome plated piston rod and wiper seals to keep out corrosion and contamination in a shop environment.
- Presses with single-acting cylinder offer choice of 2-speed hand operated, electric/hydraulic, or air/hydraulic pump. Models with double-acting cylinder have an electric/hydraulic pump.
- Press model equipped with remote control enables operator to view work from all sides with fingertip control of cylinder piston travel.
- Press can be used horizontally for special applications with user-supplied support legs.

• PUMP ELECTRICAL SPECIFICATIONS

PE17 Series – .37 kW, 220 volt, 50 cycle, single phase. Also available in 115 volt, 60 cycle.

PE21 Series – .74 kW, 220 volt, 50 cycle, single phase. Also available in 115 volt, 60 cycle.

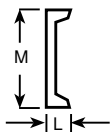

Lower Bolster

PQ60 Series – 1.49 kW, 220 volt, 60 cycle, single phase. Also available in 230 volt, 60 cycle.

To order presses with 115 volt, 60 cycle pumps, remove suffix "-220" from order no.

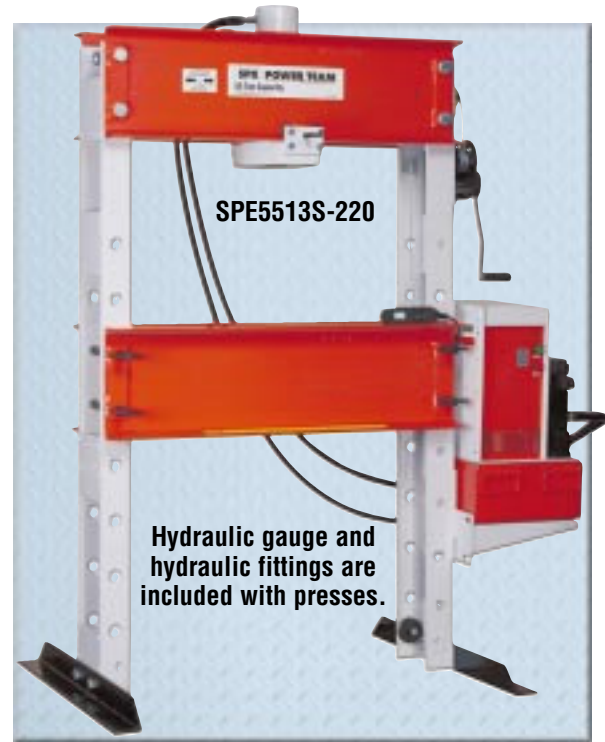

Hydraulic gauge and hydraulic fittings are included with presses.

SHOP EQUIPMENT

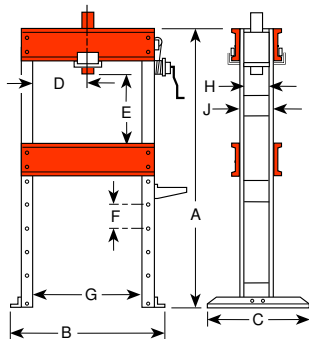

DIMENSIONS

A (mm)	B (mm)	C (mm)	D* (mm)	E (mm)	F (mm)	G (mm)	H (mm)	J (mm)	L (mm)	M (mm)	Floor Space (mm)
1,829	1,232	914	83-832	152-1,067	152	914	171	203	76	305	1,232 x 914

* Lateral head movement

ORDERING INFORMATION

Cap. (tons)	Type of Cylinder Used	Stroke	Cylinder Model	Order No.	Speed (mm/min.)†††		Pump Type	Valve Type	Pump‡ Model	Prod. Wt. (kg)
					Advance	Pressing				
55	Single-Acting	159 mm	C556C	SPA556	114.3	12.7	Air	2-Way Foot	PA6	318
55	Single-Acting	159 mm	C556C	SPM556	5.8 mm/stroke	0.4 mm/stroke	Hand	Load-Release	P159	323
55	Single-Acting	337 mm	C5513C	SPM5513	16.9 mm/stroke	0.7 mm/stroke	Hand	2-Way	P460	435
55	Single-Acting	159 mm	C556C	SPE556-220	551.2	38.1	Elec.	2-Way††	PE172-50-220	333
55	Single-Acting	337 mm	C5513C	SPE5513-220	551.2	38.1	Elec.	2-Way††	PE172-50-220	444
55	Single-Acting	337 mm	C5513C	SPE5513S-220	620	48.3	Elec.	3-Way†	PE213S-50-220	478
55	Double-Acting	333 mm	RD5513	SPE5513D-220	551	38.1	Elec.	4-Way	PE174-50-220	450
55	Double-Acting	333 mm	RD5513	SPE5513DS-220	1,679	137.2	Elec.	4-Way†	PQ604S-50-220	505

* Frame is shipped assembled.

† Solenoid valve with 24 volt remote control hand switch.

†† Holds pressure with motor shut off. Also has an automatic dump setting. Furnished with a 3.1 m remote motor control.

††† Typical performance based on 7 bar and 700 bar pump specifications. Actual speeds may vary with operating conditions.

‡ Pump standard with press. Other Power Team pumps can be substituted. dBA at idle and 700 bar: PE172—67/81; PE21 Series—70;

PQ60—74/76; measured at 1 m distance, all sides.



SF50

No. SF50 – Straightening fixtures for use with 55-ton shop or 80-ton Roll-Bed® presses (2 ea.). Wt., 47.2 kg. Not part of press, order separately.