

Bench/Floor H Frame Presses

10 Ton Capacity

SHOP EQUIPMENT

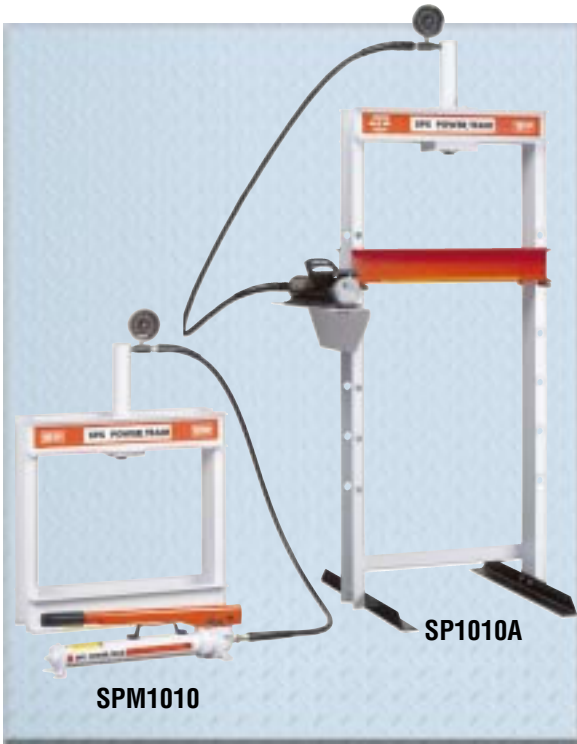

- Ideal for small pressing jobs; repairing small motors, armatures, removing and installing gears, bearings, other press-fit parts.
- Bench press has 391 x 457 mm work area; floor press bed height is adjustable from 127 to 1,041 mm with horizontal “daylight” of 553 mm.
- Choices of power sources: single-speed hand pump, electric/hydraulic or air/hydraulic.
- Hydraulic gauges, hoses and fittings included.
- PUMP ELECTRICAL SPECIFICATIONS
PE10 Series – .19 kW, 220 volt, 50 cycle, single phase. Also available in 115 volt, 60 cycle, remove suffix “-220” from order number.

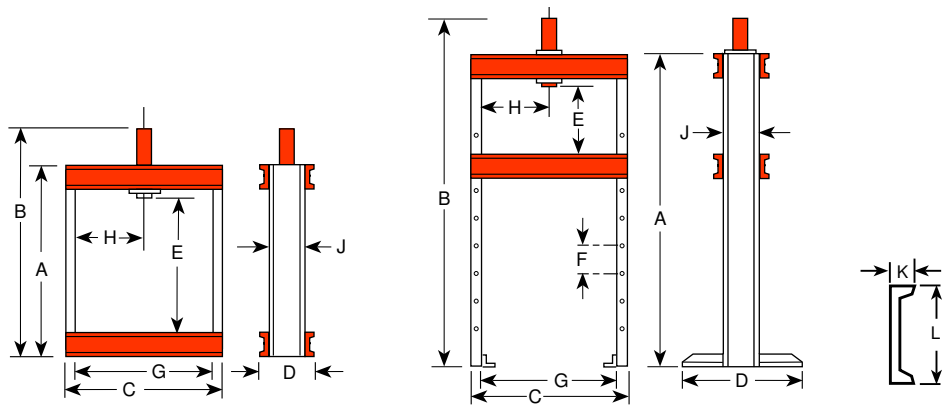

DIMENSIONS

Frame	A (mm)	B (mm)	C (mm)	D (mm)	E (mm)	F (mm)	G (mm)	H (mm)	J (mm)	K (mm)	L (mm)	Bench Space (mm)	Floor Space (mm)
Bench	622	841	641	182	391	—	559	279	102	40	102	182 x 641	—
Floor	1,499	1,718	641	711	127-1,041	152	559	63.5-470*	102	40	102	—	711 x 730

* Lateral head movement

ORDERING INFORMATION

Frame	Cap. (tons)	Type of Cyl. Used	Stroke	Cylinder Model	Order No.	Speed (mm/min.)†††		Type Pump	Pump Model †	Prod. Wt. (kg)
						Advance	Pressing			
222481 Bench	10	Single-Acting	257 mm	C1010C	SPM1010	1.5 mm/stroke		Hand	P55	41.2
222480 Floor	10	Double-Acting	257 mm	C1010C	SPH1010	1.5 mm/stroke		Hand	P55	77.5
222480 Floor	10	Double-Acting	257 mm	C1010C	SPE1010-220	5.1	55.7	Elec. ††	PE102-220	79.3
222480 Floor	10	Double-Acting	257 mm	RD1010	SP1010A	7.6	93.7	Air	PA9H	78.1
222480 Floor	10	Double-Acting	254 mm	RD1010	SPE1010D-220	5.1	55.7	Elec. ††	PE104-220	87.0

† Optional air/hydraulic pumps available on request.

†† “Advance” position holds pressure with motor shut off. “Return” position advances cylinder with motor running and returns cylinder with motor shut off.

††† Typical performance based on 7 bar and 700 bar pump specifications. Actual speeds may vary with operating conditions.