

# Mechanical Jaw Pullers

## 1-25 Ton Capacity, 2 & 2/3 Jaw Pullers

Pullers designed to pull gears, bearings and countless other press fitted parts.

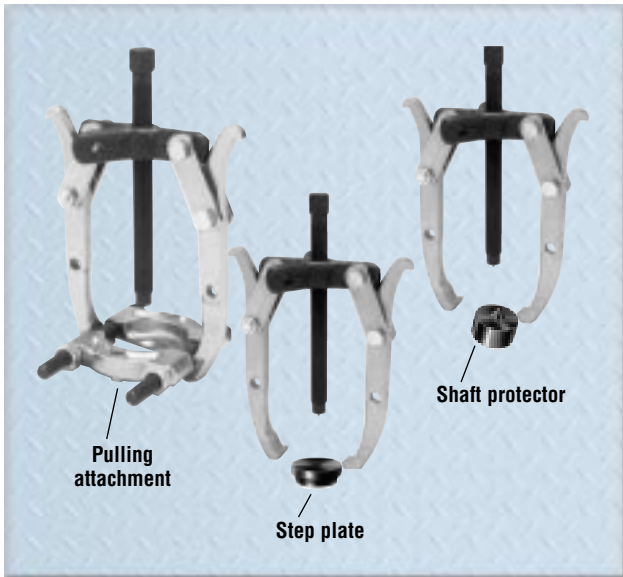

- Grip-O-Matic® feature on all pullers. The harder the pull, the tighter the grip for removing gears, bearings and countless other press fitted parts.
- 2-way, 3-way and 2/3 way combination pullers make it easy to select a specific puller for a specific application.
- Forged from high quality steel, heat treated and subjected to rigorous tests which exceed rated puller capacity.
- Alloy steel heads are forged for maximum strength.
- Forcing screw threads are rolled, not cut. This process creates a smoother and stronger thread.
- Heat treated alloy steel cross bolts for maximum shear strength.
- Machined puller jaw toes produce larger and stronger pulling toes.



**Choosing the right size puller:**  
Compare the “reach” and “spread” of the pulling job with that of the pullers listed. The puller selected must have dimensions greater than those of the job.



Fed. Spec.: GGG-P-00781-D

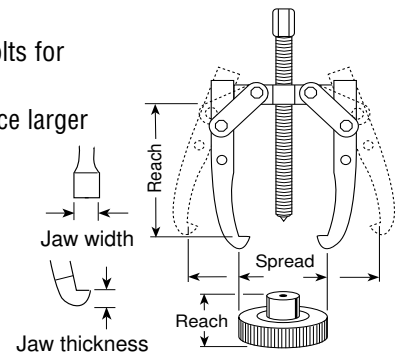
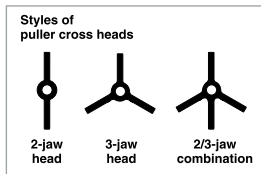

### 1 ton capacity, standard jaw puller

#### 2 Jaw

- A No. 1020** – Wt., 142 g  
Reach: 54 mm max.  
Spread: 82.6 mm max.  
Screw Size: 5/16"–24 x 98.4 mm lg.

#### 3 Jaw

- B No. 1021** – Wt., 227 g  
Reach: 54 mm max.  
Spread: 82.6 mm max.  
Screw Size: 5/16"–24 x 98.4 mm lg.

### 2 ton capacity, reversible jaw puller

#### 2 Jaw\*

- C No. 1022** – Wt., 396 g  
Reach: 85.7 mm max.  
Spread: 101.6 mm max.  
Screw Size: 3/8"–24 x 124 mm lg.

#### 2/3 Jaw\*

- D No. 1023** – Wt., 0.6 kg  
Reach: 85.7 mm max.  
Spread: 121 mm max.  
Screw Size: 3/8"–24 x 124 mm lg.

### 5 ton capacity, reversible jaw puller

#### 2 Jaw\*

- E No. 1024** – Wt., 0.8 kg  
Reach: 83 mm max.  
Spread: 152 mm max.  
Screw Size: 9/16"–20 x 176 mm lg.

#### 2/3 Jaw\*

- F No. 1026** – Wt., 1.3 kg  
Reach: 83 mm max.  
Spread: 178 mm max.  
Screw Size: 9/16"–20 x 176 mm lg.

### 5 ton capacity, reversible jaw puller

#### 2 Jaw\*

- G No. 1025** – Wt., 0.9 kg  
Reach: 140 mm max.  
Spread: 152 mm max.  
Screw Size: 9/16"–20 x 176 mm lg.

#### 2/3 Jaw\*

- H No. 1027** – Wt., 1.5 kg  
Reach: 140 mm max.  
Spread: 178 mm max.  
Screw Size: 9/16"–20 x 178 mm lg.

\* With double-end, reversible jaws.

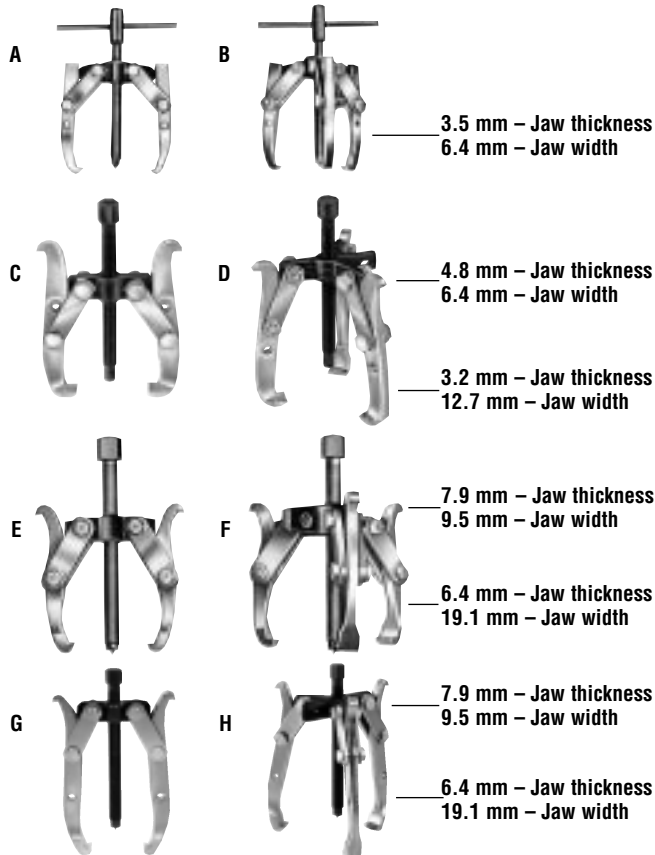

For puller piece part identification, order Power Team parts catalog PC97

## 7 ton capacity, reversible jaw puller

### 2 Jaw\*

**J** **No. 1035** – Wt., 2 kg  
Reach: 127 mm max.  
Spread: 229 mm max.  
Screw Size: 11/16"–18 x 229 mm lg.

### 2/3 Jaw\*

**K** **No. 1037** – Wt., 2.8 kg  
Reach: 127 mm max.  
Spread: 267 mm max.  
Screw Size: 11/16"–18 x 229 mm lg.

## 7 ton capacity, long jaw puller

### 2 Jaw

**L** **No. 1036** – Wt., 2.3 kg  
Reach: 222 mm max.  
Spread: 241 mm max.  
Screw Size: 11/16"–18 x 229 mm lg.

### 2/3 Jaw

**M** **No. 1038** – Wt., 3.3 kg  
Reach: 222 mm max.  
Spread: 279 mm max.  
Screw Size: 11/16"–18 x 229 mm lg.

## 13 ton capacity, standard and long jaw pullers

### Std. 2 Jaw

**N** **No. 1039** – Wt., 4.8 kg  
Reach: 279 mm max.  
Spread: 318 mm max.  
Screw Size: 13/16"–16 x 305 mm lg.

### Long 2 Jaw

**N** **No. 1040** – Wt., 5.9 kg  
Reach: 387 mm max.  
Spread: 279 mm max.  
Screw Size: 13/16"–16 x 305 mm lg.

### Std. 2/3 Jaw

**O** **No. 1041** – Wt., 6.7 kg  
Reach: 279 mm max.  
Spread: 356 mm max.  
Screw Size: 13/16"–16 x 305 mm lg.

### Long 2/3 Jaw

**O** **No. 1042** – Wt., 8.3 kg  
Reach: 387 mm max.  
Spread: 432 mm max.  
Screw Size: 13/16"–16 x 305 mm lg.

## 17 1/2 ton capacity, standard and long jaw pullers

### Std. 2 Jaw

**P** **No. 1043** – Wt., 10.4 kg  
Reach: 386 mm max.  
Spread: 356 mm max.  
Screw Size: 1"–14 x 343 mm lg.

### Long 2 Jaw

**P** **No. 1044** – Wt., 11.8 kg  
Reach: 476 mm max.  
Spread: 406 mm max.  
Screw Size: 1"–14 x 343 mm lg.

### Std. 3 Jaw

**Q** **No. 1045** – Wt., 15 kg  
Reach: 386 mm max.  
Spread: 356 mm max.  
Screw Size: 1"–14 x 343 mm lg.

### Long 3 Jaw

**Q** **No. 1046** – Wt., 16.8 kg  
Reach: 476 mm max.  
Spread: 406 mm max.  
Screw Size: 1"–14 x 343 mm lg.

## 25 ton capacity, standard and long jaw pullers

### Std. 2 Jaw

**R** **No. 1047** – Wt., 17 kg  
Reach: 394 mm max.  
Spread: 406 mm max.  
Screw Size: 1 1/4"–12 x 422 mm lg.

### Long 2 Jaw

**R** **No. 1048** – Wt., 19.4 kg  
Reach: 565 mm max.  
Spread: 508 mm max.  
Screw Size: 1 1/4"–12 x 422 mm lg.

### Std. 3 Jaw

**S** **No. 1049** – Wt., 24.5 kg  
Reach: 394 mm max.  
Spread: 406 mm max.  
Screw Size: 1 1/4"–12 x 422 mm lg.

### Long 3 Jaw

**S** **No. 1050** – Wt., 27.2 kg  
Reach: 565 mm max.  
Spread: 508 mm max.  
Screw Size: 1 1/4"–12 x 422 mm lg.

